

HPI 5

Manual

Content

1	Getting started	3
2	System Overview	4
3	Injection Valve Control	5
4	Firing Sequence	6
5	High Pressure Pump Control	7
6	CAN Interface	8
6.1	Overview CAN Messages	8
6.2	Message DI_BOX2	8
6.2.1	Message Structure	8
6.2.2	Diagnosis registers of the injection valve powerstage	9
6.2.3	Coding of the injector diagnosis bit	10
6.3	Message DI_BOX3	10
6.4	Message EMS7	12
7	Technical Specification	14
7.1	Operating Conditions	14
7.2	Connector	14
7.3	Pin Description	15
7.4	Electrical Characteristics	16

1 Getting started

Important Notes:

Use the ECU HPI 5 only as intended in this manual. Any maintenance or repair must be performed by authorized and qualified personnel approved by Bosch Motorsport.

Operation of the ECU HPI 5 is only certified with the combinations and accessories that are specified in this manual. The use of variant combinations, accessories, and other devices outside the scope of this manual are only permitted if they have been determined to be compliant from a performance and safety standpoint by a representative from Bosch Motorsport.



DANGER

High Voltage of GDI (Gasoline Direct Injection) - Solenoid valve injection

One special characteristic of a gasoline direct injection system (solenoid valve) is the high voltage of the power stage of more than 65 V (at very low environment temperatures up to 72 V), which entails risk of life.

Disclaimer:

Due to continuous enhancements we reserve the rights to change any illustrations, photos and technical data within this manual.

Please retain this manual for your records.

2 System Overview

The injector power stage HPI 5 is a device for driving injectors and high pressure pumps for gaso-line direct injection (GDI).

Combined with a suitable motor management ECU up to 8 injectors (depending on engine parameters like maximum speed) and 2 high pressure pumps can be driven. The injectors are gathered in four groups of 2 injectors each. Within a group only one injector can be switched on at the same time.

The HPI 5 is connected to the main ECU by CAN interface for configuration/diagnosis and by signal lines for injector and pump control.

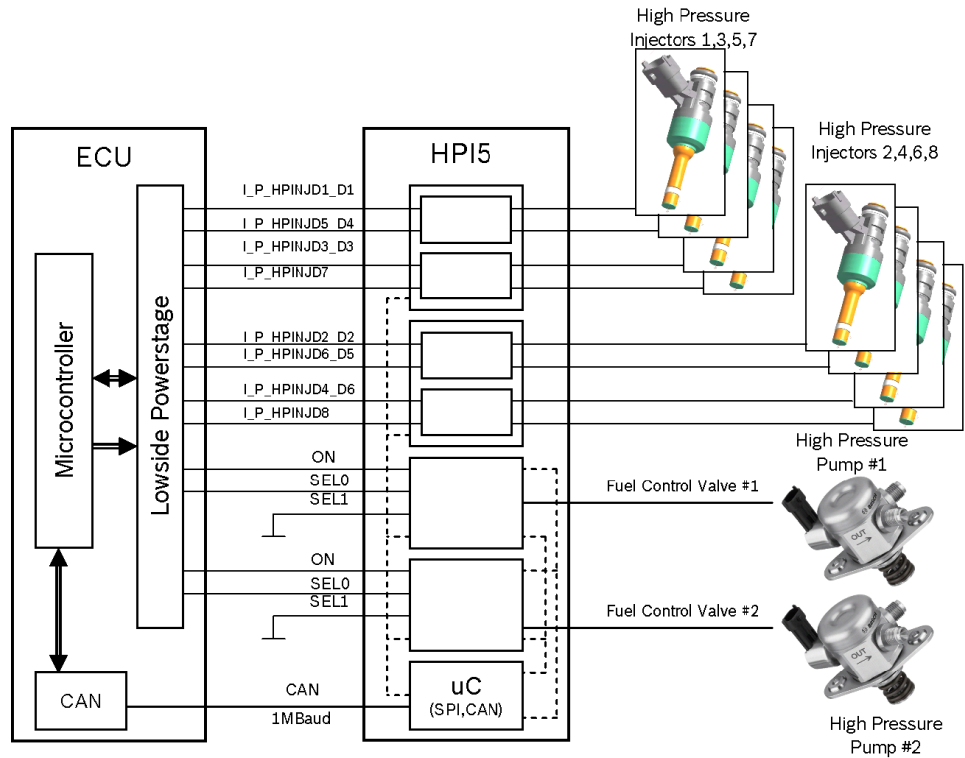

Illustration 1: Block Diagram of HPI 5 with Engine Control Unit (ECU) and actuators

3 Injection Valve Control

High Pressure Injection Valves (HDEVs) need a specific current control. This consists of three phases:

1. Booster Phase
2. Pick-Up Phase
3. Holding Phase

During the Booster Phase the booster voltage of approx. 65 V is applied to the injector in order to achieve a fast current increase. After reaching a specified current or reaching a specified booster time, the HPI 5 switches to the Pick-Up Phase. In this phase the injector is opened by battery supply voltage. After a specified pick-up time the HPI 5 switches to the Holding Phase. During this phase the injector current is regulated to a level necessary to keep the valve open.

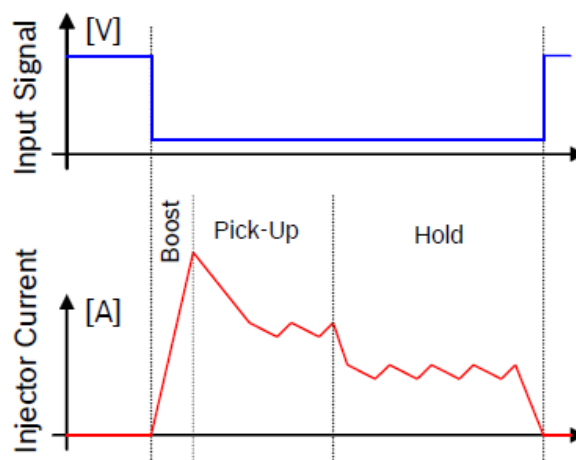

Illustration 2: Typical Injector Current

The timing and current parameters are configured to drive Bosch HDEV 5 injectors.

4 Firing Sequence

When assigning injector power stages to the high pressure injectors, two items must be considered:

Two injectors connected to the same high side switch cannot be activated at the same time. Therefore the distance between these injectors in the firing order should be as large as possible.

The output power of each DC/DC converter limits the number of possible injections. To achieve maximum engine speed each DC/DC converter should supply the same amount of injectors.

The structure of the power stage is shown in the following figure.

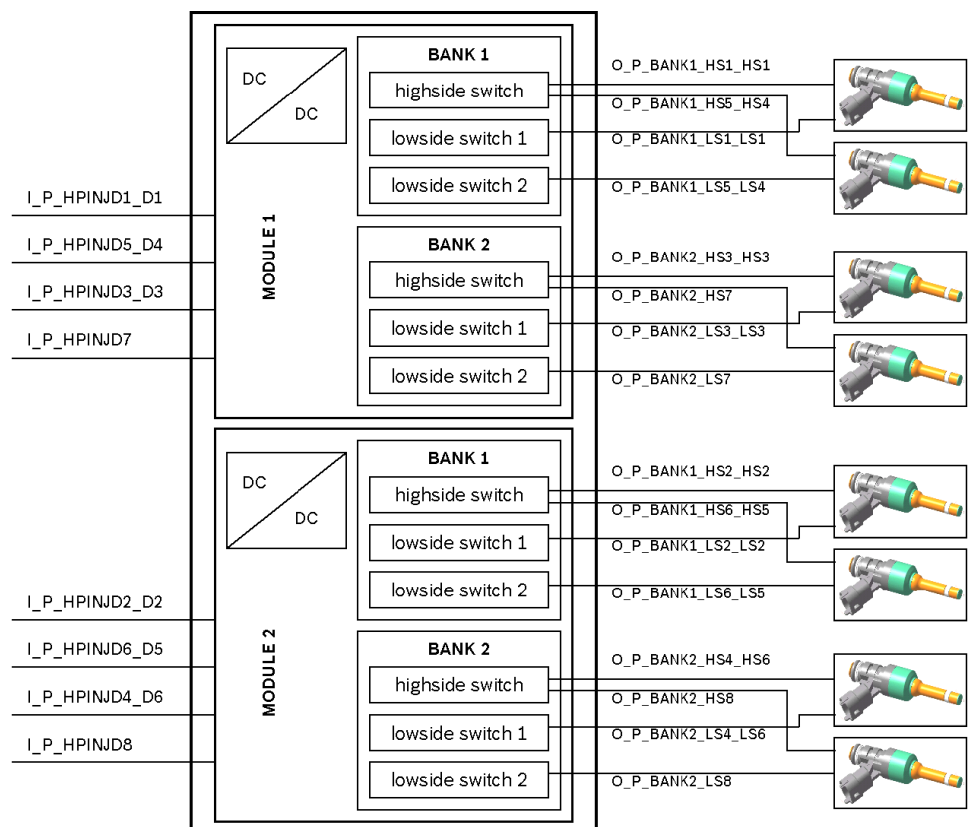

Illustration 3: Internal structure of the injector power stage

The recommended firing order for a 4 cylinder engine is:

I_P_HPIINJD1_D1 -> I_P_HPIINJD2_D2 -> I_P_HPIINJD3_D3 -> I_P_HPIINJD4_D6

The recommended firing order for a 6 cylinder engine is:

I_P_HPIINJD1_D1 -> I_P_HPIINJD2_D2 -> I_P_HPIINJD3_D3 -> I_P_HPIINJD5_D4 ->
I_P_HPIINJD6_D5 -> I_P_HPIINJD4_D6

The recommended firing order for an 8 cylinder engine is:

I_P_HPIINJD1_D1 -> I_P_HPIINJD2_D2 -> I_P_HPIINJD3_D3 -> I_P_HPIINJD4_D6 ->
I_P_HPIINJD5_D4 -> I_P_HPIINJD6_D5 -> I_P_HPIINJD7 -> I_P_HPIINJD8

When driving engines with less than 8 cylinders please connect the injectors according to the comments above.

5 High Pressure Pump Control

The Bosch High Pressure Pump HDP 5 is driven by the camshaft. The fuel flow is regulated by the Fuel Control Valve. The power stage to drive this valve is integrated into the HPI 5.

The input signals for the power stage (ON, SEL0) are received from the Engine Control Unit. SEL1 must be connected to ground.

The power stage is not active after startup. It must be activated with the correct CAN message.

Details of the high pressure pump control are described in the function sheet of the Engine Control Unit.

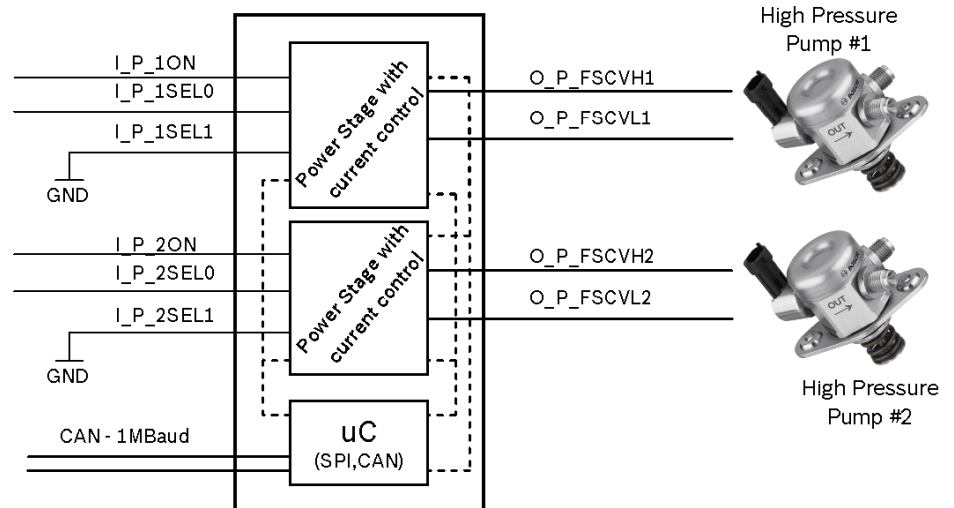

Illustration 4: Structure of the high pressure pump control

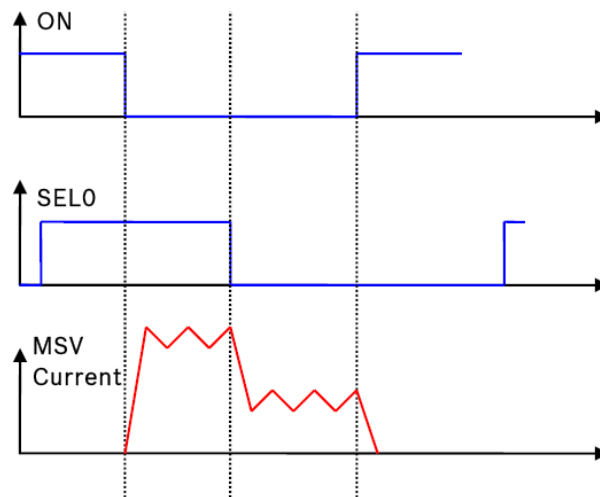

Illustration 5: Typical Control Trace

6 CAN Interface

The CAN interface of the HPI 5 is configured to 1 Mbaud transmission rate. There is no termination resistor within the HPI 5.

6.1 Overview CAN Messages

Message	Identifier	Sender	Output period	Message timeout
DI_BOX2 *)	0x546	HPI 5	100 ms	-
DI_BOX3	0x380	HPI 5	20 ms	-
EMS7	0x384	ECU	20 ms	500 ms

*) Message DI_BOX2 is send only if bit CanDI_bInjVdhdevrj is set to 1 (see message EMS7).



NOTICE

The following CAN-IDs are reserved for HPI 5 internal reasons and must not be used on the CAN bus(es) the HPI 5(s) is/are connected to: 0x30, 0x6A5, 0x6A6, 0x6A9, 0x7B2, 0x7BA, 0x7DF

6.2 Message DI_BOX2

6.2.1 Message Structure

Signal label CAN	Signal designation	Bit address	Bit length	Label DI-Box	Default/ Init value
CanDI_InjVDia-gRxRAM00 *)	Diagnosis 0 register of first 0 injection valve powerstage		8	InjVlvPs_Dia-gRxRAM00	0
CanDI_InjVDia-gRxRAM01 *)	Diagnosis 1 register of first 8 injection valve powerstage		8	InjVlvPs_Dia-gRxRAM01	0
CanDI_InjVDia-gRxRAM02 *)	Diagnosis 2 register of first 16 injection valve powerstage		8	InjVlvPs_Dia-gRxRAM02	0
CanDI_InjVDia-gRxRAM10 *)	Diagnosis 0 register of first 24 injection valve powerstage		8	InjVlvPs_Dia-gRxRAM10	0
CanDI_InjVDia-gRxRAM11 *)	Diagnosis 1 register of first 32 injection valve powerstage		8	InjVlvPs_Dia-gRxRAM11	0
CanDI_InjVDia-gRxRAM12 *)	Diagnosis 2 register of first 40 injection valve powerstage		8	InjVlvPs_Dia-gRxRAM12	0
CanDI_uBattDI	Battery voltage (on board); 48 quantization 0.1 V/bit		8	Ubsq	0
CanDI_bInjV-DiagRespErr1	Set, if there is a wrong SPI check-byte (second injection valve power stage)	56	1	InjVlvPs_Dia-gRespErr1	FALSE

Signal label CAN	Signal designation	Bit ad- dress	Bit length	Label DI-Box	Default/ Init value
CanDI_bInjV- DiagRespErr0	Set, if there is a wrong SPI check-byte (first injection valve power stage)	57	1	InjVlvPs_Dia- gRespErr0	FALSE
CanDI_bInjV- DiagSPIErr1	No SPI communication (second injection valve power stage)	58	1	In- jVlvPs_DiagS- PIErr1	FALSE
CanDI_bInjV- DiagSPIErr0	No SPI communication (first injection valve power stage)	59	1	In- jVlvPs_DiagS- PIErr0	FALSE

*) CanDI_InjVDiagRxRAMxx-information is valid only, if bit CanDI_bInjVdhdevee is set to 1 (see message EMS7).

6.2.2 Diagnosis registers of the injection valve powerstage

Diagnosis register 0

Bit	Name	Reset value	Description
7	Not ERROR	0	Common error status bit
6	Not B1_ERR	1	0 = Error in bank 1, reading of Diagnosis register 1 is necessary
5	Not B2_ERR	1	0 = Error in bank 2, reading of Diagnosis register 2 is necessary
4	-	1	Not used
3	Not TEMP	1	0 = overtemperature warning
2	ENAB	1	Current status of the ENAB-input is given back
1	Not CLKRES	0	0 : missing clock or state machine was in reset mode
0	Not URES	0	0 after Reset and if VCC-undervoltage detected by internal monitor

Diagnosis register 1

Reset value: '1111 1111'

7	6	5	4	3	2	1	0
Diagnosis of Injector 11 (HPINJD1_D1 / HPINJD2_D2)				Diagnosis of Injector 12 (HPINJD5_D4 / HPINJD6_D5)			
Bit3	Bit2	Bit1	Bit0	Bit3	Bit2	Bit1	Bit0

Diagnosis register 2

Reset value: '1111 1111'

7	6	5	4	3	2	1	0
Diagnosis of Injector 21 (HPINJD3_D3 / HPINJD4_D6)				Diagnosis of Injector 22 (HPINJD7 / HPINJD8)			
Bit3	Bit2	Bit1	Bit0	Bit3	Bit2	Bit1	Bit0

6.2.3 Coding of the injector diagnosis bit

Bit3	Bit2	Bit1	Bit0	Name	Reaction
0	0	0	0	Short circuit to ground of HPIVxy-low-side	No reaction
0	0	1	0	Short circuit to ground of HPIVxy-high-side	High-side drive x and Low-side driver xy are turned off
0	1	0	0	No load	No reaction
0	1	1	0	Short circuit of HPIVxy-low-side and high-side	High-side drive x and Low-side driver xy are turned off
1	0	0	0	Short circuit to power supply by HPIVxy-low-side	High-side drive x and Low-side driver xy are turned off
1	0	1	0	Short circuit to power supply by HPIVxy-high-side	No reaction
1	1	0	0	Booster Timeout	No reaction
1	1	1	0	Short circuit to ground or to power supply of HPIVxy-booster-high-side	State machine turns over to Pickup phase for error detection and coding
1	1	1	1	No error detected	No reaction

6.3 Message DI_BOX3

Message Structure

Signal label CAN	Signal designation	Bit address	Bit length	Label DI-Box	Default/Init value
CanDI_stInjVlc	Configuration state of the high-pressure injection valve powerstages Indicates, if there are difference between written and read PARACON registers. If InjVlvPs_stIC=0 then no differences were found.	0	8	InjVlvPs_stIC	0
CanDI_stInjVChkSt0	State first high-pressure injection valve powerstage Indicates, if the HDEV power stage could be initialized. If 1, the first HDEV power stage could be initialized.	8	8	InjVlvPs_stCheckStateM[0]	0
CanDI_stInjVChkSt1	State second high-pressure injection valve powerstage	16	8	InjVlvPs_stCheckStateM[1]	0

Signal label CAN	Signal designation	Bit ad- dress	Bit length	Label DI-Box	Default/ Init value
	Indicates, if the HDEV power stage could be initialized. If 1, the second HDEV power stage could be initialized.				
CanDI_InjVh- devpup	Pickup phase high-pressure injection valve powerstage	24	8	In- jVlvPs_hdevp up	0
CanDI_InjVh- devbpt	Booster phase timeout high-pressure injection valve powerstage	32	8	In- jVlvPs_hdevb pt	0
CanDI_MFV- ValveErr1	Error register contents of first MSV powerstage	40	8	mfpsconcy_V alveErr[0]	0
CanDI_MFV- ValveErr2	Error register contents of second MSV powerstage	48	8	mfpsconcy_V alveErr[1]	0
CanDI_bM- FVSPi2Err	The SPI error on second MSV powerstage	56	1	mfpsconcy_b SPi2Err	FALSE
CanDI_bM- FVSPi1Err	The SPI error on first MSV powerstage	57	1	mfpsconcy_b SPi1Err	FALSE
CanDI_bM- FVID2Err	The second MSV powerstage ID error	58	1	mfpsconcy_bI D2Err	FALSE
CanDI_bM- FVID1Err	The first MSV powerstage ID error	59	1	mfpsconcy_bI D1Err	FALSE
CanDI_bMF- VInitSuc	The initialization status of MSV powerstage	60	1	mfpsconcy_bI nitSuccess	FALSE
CanDI_bCANE- rr	- not used -	61	1	-	-

Error register of MSV power stages

Bit	Error
7	Valid bit
6	Not used
5	Fast decay error
4	Load loss
3	Fast rising edge
2	Prediagnosis error
1	Overcurrent low side
0	Overcurrent high side

6.4 Message EMS7

Message Structure

Signal label CAN	Signal designation	Bit address	Bit length	Label DI-Box	Default/ Init value
CanDI_iPickup- MFV	The Pickup current to MSV powerstage (see table below)	0	8	Com_iM- FVlvPickup	0
CanDI_iHld	The Hold current to MSV powerstage (see table below)	8	8	Com_iHld	0
CanDI_In- jVbnkEnbl	Bank activated at injection valve powerstages (see table below)	16	8	Com_stIn- jVlvBnkEnbl	0
CanDI_bln- jVdhdevee	Conditions HDEV powerstage diagnosis fulfilled. Must be set to enable injection valve diagnosis	32	1	Com_blnjVd- hdevee	FALSE
CanDI_sw- tOffCy202_1*)	The flag to switch off first CY202 IC (high pressure pump #1 switched off)	33	1	Com_sw- tOffCy202_1	FALSE
CanDI_sw- tOffCy202_2*)	The flag to switch off second CY202 IC (high pressure pump #2 switched off)	34	1	Com_sw- tOffCy202_2	FALSE
CanDI_bln- jVdhdevrq	Request to read HDEV powerstage diagnosis result (CAN message DI_BOX2 is sent by HPI 5)	38	1	Com_blnjVd- hdevrq	TRUE
CanDI_dcMFV	Duty-cycle of holding phase for PWM-control of the MSV (not used)	40	8	Com_dcM- FVlv	0
CanDI_uBat- tEMS	Battery voltage via main relay; quantization 0.1 V/bit	48	8	Com_uBat- tEMS	0
CanDI_stInjV- ParSentence	Activated parameter sentence at injection valve powerstage. Must be set to 1.	56	8	Com_stInjVlv- ParRcrd	1

*) For HPI 5 internal reasons, even if just one high pressure pump is used, it's recommended to enable both channels (CanDI_swOffCy202_1 = FALSE and CanDI_swOffCy202_2 = FALSE) to make sure the reinitialization of the CY202 ICs is performed correctly after a CAN-failure.

Values for pickup and hold current of MSV power stage

(values for Bosch HDP 5 and 30 mOhm shunt). Bits 4 to 0

Setting	Condition	Setting	Condition	Setting	Condition	Setting	Condition
00000	2.67 A	01000	3.73 A	10000	4.8 A	11000	5.87 A

Setting	Condition	Setting	Condition	Setting	Condition	Setting	Condition
00001	2.8 A	01001	3.87 A	10001	4.93 A	11001	6 A
00010	2.93 A	01010	4 A	10010	5.07 A	11010	6.13 A
00011	3.07 A	01011	4.13 A	10011	5.2 A	11011	6.26 A
00100	3.2 A	01100	4.27 A	10100	5.33 A	11100	6.4 A
00101	3.33 A	01101	4.4 A	10101	5.47 A	11101	6.53 A
00110	3.47 A	01110	4.53 A	10110	5.6 A	11110	6.67 A
00111	3.6 A	01111	4.67 A	10111	5.73 A	11111	6.8 A

Values for pickup and hold current hysteresis of MSV power stage

(values for Bosch HDP 5 and 30 mOhm shunt). Bits 7 to 5

Setting	Condition
000	0.4 A
001	0.53 A
010	0.67 A
011	0.8 A

Example:

Pickup current of 5.2 A with hysteresis of 0.67 A: CanDliPickupMFV = 01010011 = 53 hex

Hold current of 3.07 A with hysteresis of 0.4 A: CanDliHld = 00000011 = 03 hex

Inj valve bank enable register (CanDI_InjVBnkEnbl)

Bit	Enabled injector channel
7	HPINJD1_D1
6	HPINJD5_D4
5	HPINJD3_D3
4	HPINJD7
3	HPINJD2_D2
2	HPINJD6_D5
1	HPINJD4_D6
0	HPINJD8

7 Technical Specification

Mechanical Data

Housing	Aluminum EPA0913 (details see offer drawing)
Connector	Plastic
Mounting position	Chassis (No direct mounting on engine!)
Water protection	Splash protected
Weight	Approx. 550 g

Storage Conditions

Storage temperature	-40 to 40°C
Storage rel. humidity	30 to 60 %

7.1 Operating Conditions

Parameter	Condition / Comment	Symbol	min	max	Unit
Supply voltage	Operation voltage (full functionality)	U_BAT	10	16	V
	Nominal operating voltage	U_BAT	12	14	V
	Engine start	U_BAT	6.5	16	V
	Overvoltage (1min)	U_BAT		24	V
Ambient temperature		T	-40	+80	°C
Engine speed	Injection control*) single injection	nmot	7000	rpm	Injection control*) single injection
Injection time	Single injection at maximum engine speed	ti	4.5	ms	Single injection at maximum engine speed

*) Message DI_BOX2 is sent only, if bit CanDI_bInjVdhdevrq is set to 1 (see message EMS7).

7.2 Connector

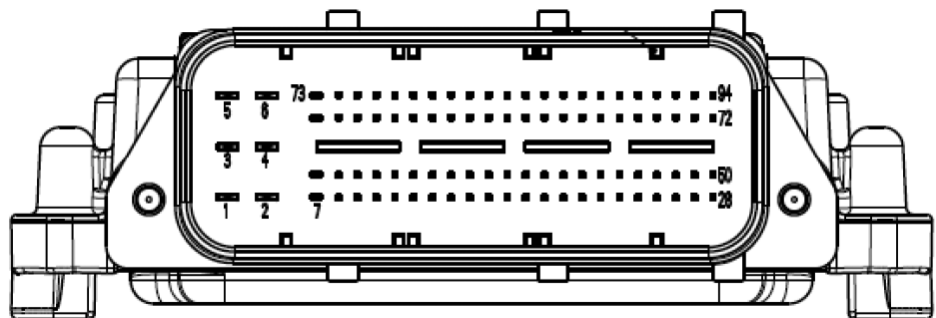

Illustration 6: 94 pin Male Connector

94 pin Male Connector Tin-coated:

6 pins of dimension 2.8mm x 0.8mm = 2.24 mm²

4 pins of dimension 1.5mm x 0.6mm = 0.9 mm²

84 pins of dimension 0.63mm x 0.63mm = 0.4 mm²

7.3 Pin Description

Pin	Signal	Description
1	G_G_BAT	Battery minus
2	G_G_BAT	Battery minus
3	V_V_BAT_R	Battery plus
4	G_G_BAT	Battery minus
5	V_V_BAT_R	Battery plus
6	V_V_BAT_R	Battery plus
7	O_P_FSCVL1	Flow control valve #1 output low side
29	O_P_FSCVH1	Flow control valve #1 output high side
51	O_P_FSCVL2	Flow control valve #2 output low side
54	I_P_2SEL1	Flow control valve #2, input signal "SEL1"
55	I_P_1SEL1	Flow control valve #1, input signal "SEL1"
56	I_P_1ON	Flow control valve #1, input signal "ON"
57	I_P_HPINJD4_D6	Injector control, input signal for injector #4 (6-cyl. engine: #6)
58	I_P_HPINJD7	Injector control, input signal for injector #7 (6-cyl. engine: not used)
59	I_P_HPINJD6_D5	Injector control, input signal for injector #6 (6-cyl. engine: #5)
60	I_P_HPINJD5_D4	Injector control, input signal for injector #5 (6-cyl. engine: #4)
64	I_S_T15	Input "Terminal 15" (Ignition switch)
65	O_P_BANK1_LS1_LS1	Injector control output, Low side of HDEV Injector #1 (6-cyl. engine: #1)
66	O_P_BANK1_HS1_HS1	Injector control output, High side of HDEV Injector #1 (6-cyl. engine: #1)
67	O_P_BANK2_HS3_HS3	Injector control output, High side of HDEV Injector #3 (6-cyl. engine: #3)
68	O_P_BANK2_LS3_LS3	Injector control output, Low side of HDEV Injector #3 (6-cyl. engine: #3)
69	O_P_BANK1_LS2_LS2	Injector control output, Low side of HDEV Injector #2 (6-cyl. engine: #2)
70	O_P_BANK1_HS2_HS2	Injector control output, High side of HDEV Injector #2 (6-cyl. engine: #2)
71	O_P_BANK2_HS4_HS6	Injector control output, High side of HDEV Injector #4 (6-cyl. engine: #6)

Pin	Signal	Description
72	O_P_BANK2_LS4_LS6	Injector control output, Low side of HDEV Injector #4 (6-cyl. engine: #6)
73	O_P_FSCVH2	Flow control valve #2 output high side
75	I_P_1SELO	Flow control valve #1, input signal "SELO"
76	I_P_2SELO	Flow control valve #2, input signal "SELO"
77	I_P_2ON	Flow control valve #2, input signal "ON"
78	I_P_HPINJD8	Injector control output, Low side of HDEV Injector #8 (6-cyl. engine: not used)
80	I_P_HPINJD2_D2	Injector control, input signal for injector #2 (6-cyl. engine: #2)
81	I_P_HPINJD1_D1	Injector control, input signal for injector #1 (6-cyl. engine: #1)
82	I_P_HPINJD3_D3	Injector control, input signal for injector #3 (6-cyl. engine: #3)
84	B_D_CANH	CAN Interface, Signal "CAN High"
85	B_D_CANL	CAN Interface, Signal "CAN Low"
87	O_P_BANK1_LS5_LS4	Injector control output, Low side of HDEV Injector #5 (6-cyl. engine: #4)
88	O_P_BANK1_HS5_HS4	Injector control output, High side of HDEV Injector #5 (6-cyl. engine: #4)
89	O_P_BANK2_HS7	Injector control output, High side of HDEV Injector #7 (6-cyl. engine: not used)
90	O_P_BANK2_LS7	Injector control output, Low side of HDEV Injector #7 (6-cyl. engine: not used)
91	O_P_BANK1_LS6_LS5	Injector control output, Low side of HDEV Injector #6 (6-cyl. engine: #5)
92	O_P_BANK1_HS6_HS5	Injector control output, High side of HDEV Injector #6 (6-cyl. engine: #5)
93	O_P_BANK2_HS8	Injector control output, High side of HDEV Injector #8 (6-cyl. engine: not used)
94	O_P_BANK2_LS8	Injector control output, Low side of HDEV Injector #8 (6-cyl. engine: not used)

7.4 Electrical Characteristics

Terminal 15 inputI_S_T15

Parameter/ Signal	Conditions/ Comments	Symbol	Values min	Values typ.	Values max	Unit
Internal pull-up resistor	Resistor connected to G_G_BAT	R		2.87		kΩ
Threshold ON		U_on	7.25			V
Threshold OFF		U_off			3.61	V

Flow Control Valve Input Signals I_P_xON; I_P_xSEL0; I_P_xSEL1

Parameter/ Signal	Conditions/ Comments	Symbol	Values min	Values typ.	Values max	Unit
Internal pull-up resistor	Resistor connected to V_V_BAT_R	R		1.08		kΩ
Threshold high		U_high	3.3			V
Threshold low		U_low			2.7	V

Injector Input Signals I_P_HPINDx_Dx

Parameter/ Signal	Conditions/ Comments	Symbol	Values min	Values typ.	Values max	Unit
Internal pull-up resistor	Resistor connected to V_V_BAT_R	R		2.15		kΩ
Threshold high		U_high	3.3			V
Threshold low		U_low			2.7	V

CAN Signals B_D_CANH, B_D_CANL

Parameter/ Signal	Conditions/ Comments	Symbol	Values min	Values typ.	Values max	Unit
Baud rate				1000		kBaud
Termination		R_Term		-		Ohm
Capacity		C			80	pF
Common mode range		V_Cmm	-12		12	V

Bosch Engineering GmbH

Motorsport

Robert-Bosch-Allee 1

74232 Abstatt

Germany

www.bosch-motorsport.com