

# PCAN-MicroMod FD

## User Manual

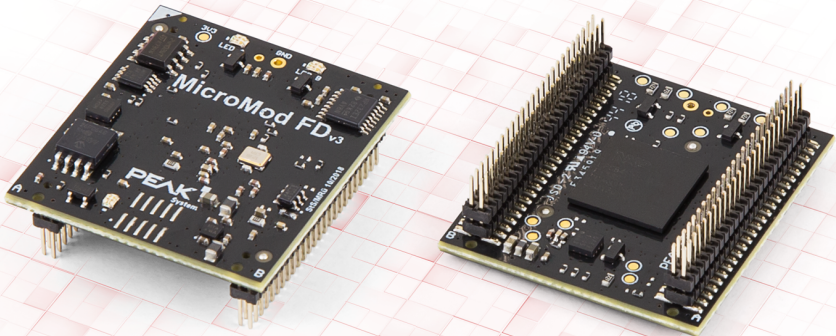

# Relevant products

<b>Product name</b>	<b>Model</b>	<b>Part number</b>
PCAN-MicroMod FD		IPEH-003080

## Imprint

PCAN® is a registered trademark of PEAK-System Technik GmbH. CANopen® and CiA® are registered community trade marks of CAN in Automation e.V. Arm and Cortex are registered trademarks of Arm Limited (or its subsidiaries) in the United States and/or elsewhere.

Other product names in this document may be the trademarks or registered trademarks of their respective companies. They are not explicitly marked by ™ or ®.

© 2019 PEAK-System Technik GmbH

Duplication (copying, printing, or other forms) and the electronic distribution of this document is only allowed with explicit permission of PEAK-System Technik GmbH. PEAK-System Technik GmbH reserves the right to change technical data without prior announcement. The general business conditions and the regulations of the license agreement apply. All rights are reserved.

PEAK-System Technik GmbH

Otto-Roehm-Strasse 69

64293 Darmstadt

Germany

Phone: +49 6151 8173-20

Fax: +49 6151 8173-29

[www.peak-system.com](http://www.peak-system.com)

[info@peak-system.com](mailto:info@peak-system.com)

Document version 1.0.0 (2019-07-10)

# Contents

<b>Relevant products</b> .....	<b>2</b>
<b>Imprint</b> .....	<b>2</b>
<b>Contents</b> .....	<b>3</b>
<b>1 Introduction</b> .....	<b>4</b>
1.1 Features Overview .....	4
1.2 Operation Requirements .....	5
1.3 Scope of Supply .....	6
<b>2 Electrical Connection</b> .....	<b>7</b>
2.1 Connectors .....	7
2.2 Circuitry .....	11
<b>3 Operation</b> .....	<b>13</b>
3.1 Status LEDs .....	13
3.2 Reserved CAN ID 7E7h .....	14
3.3 Overview of Services .....	14
<b>4 Configuration Program</b> .....	<b>16</b>
4.1 Prerequisites for the Configuration Transfer .....	16
4.2 Installing the Configuration Program .....	16
<b>5 Firmware Update</b> .....	<b>18</b>
<b>6 Technical Specifications</b> .....	<b>19</b>
<b>Appendix A Dimension Drawings</b> .....	<b>21</b>
<b>Appendix B Minimum Circuitry</b> .....	<b>22</b>
PCAN-MicroMod-FD_MinimalConnectionDiagram .....	23

# 1 Introduction

The PCAN-MicroMod FD is a small plug-in board with CAN and CAN FD connection on the one side and various physical inputs and outputs on the other side. The logical linking of both sides is done by the microcontroller NXP LPC54618. With the MicroMod FD, electronics developers can easily integrate I/O functionality with CAN connection into their project.

The PCAN-MicroMod FD is configured using the supplied Windows software. In addition to simple I/O mapping to CAN IDs, function blocks are also available for processing the data. The configuration created on the computer is transferred via the CAN bus to the MicroMod FD which then runs as an independent CAN node. Multiple modules can be configured independently on a CAN bus.

For the PCAN-MicroMod FD, ready-to-use motherboards in an aluminum housing and an evaluation board for the development of own applications are available.

This document describes the hardware and the functions of the plug-in board PCAN-MicroMod FD. Separate documents exist for the motherboards from PEAK-System (e.g. Analog 1) and for the evaluation board.

## 1.1 Features Overview

- Plug-in board with 2 double pin strips of 50 pins each, 50 mil pitch (1.27 mm)
- NXP LPC54618 microcontroller with Arm® Cortex® M4 core
- High-speed CAN connection (ISO 11898-2)
  - Complies with CAN specifications 2.0 A/B and FD
  - CAN FD bit rates for the data field (64 bytes max.) from 20 kbit/s up to 10 Mbit/s
  - CAN bit rates from 20 kbit/s up to 1 Mbit/s
  - Microchip CAN transceiver MCP2558FD

- 8 analog inputs
  - Measuring range unipolar 0 to 3 V
  - Resolution 12 bits, sample rate 1 kHz
- 8 digital inputs
- 8 digital outputs
- 2 frequency outputs
- Selective configuration of up to 16 devices in a CAN network based on the module ID
- Supply voltage 3,3 V
- Dimensions 33 x 36 mm
- Extended operating temperature range from -40 to 85 °C (-40 to +185 °F)

## 1.2 Operation Requirements

- Board with socket strips or hole grid for mounting the PCAN-MicroMod FD (Evaluation Board, motherboard from PEAK-System or self-development), see also Appendix A *Dimension Drawings* on page 21.  
Possible socket strip (2 pieces) as counterpart to the PCAN-MicroMod FD: Amtek 5PS3MSA44-225GONPNRU-00
- For the creation and transfer of a configuration:  
Computer with Windows 10, 8.1, 7 (32/64-bit) and a PC-CAN interface from PEAK-System

## 1.3 Scope of Supply

- PCAN-MicroMod FD plug-in board
- Configuration software for Windows
- Manual in PDF format
- Optional: Pin adapter for 100 mil pitch

# 2 Electrical Connection

This chapter covers the signal assignment of the pins on the PCAN-MicroMod FD and its possible circuitry.

## 2.1 Connectors

The PCAN-MicroMod FD has two double pin rows (A, B) with 50 pins each (first column in the following tables). Thus, the MicroMod FD can be plugged onto boards with matching socket strips (50-mil/1.27-mm grid, see also Appendix A *Dimension Drawings* on page 21).

Possible socket strip (2 pieces) as counterpart to the PCAN-MicroMod FD: Amtek 5PS3MSA44-225GONPNRU-00

On request, PEAK-System offers an adapter for circuit boards with 100-mil/2.54-mm grid).

The MicroMod FD has a white mark on the upper left corner (pin A1) for better orientation when plugged in.



**Attention!** Electrostatic discharge (ESD) can damage or destroy components on the circuit board. Take precautions to avoid ESD when handling the circuit board.

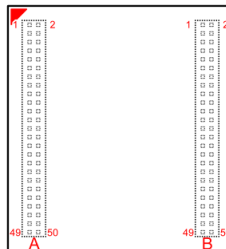

Figure 1: Pin layout of the two double pin headers,  
direction of view from above through the circuit board (orientation when plugged in).

Pin MMFD	Name	Function
A1	GND	Ground
A3	LED-A_red	Open-drain outputs for external status LEDs
A5	LED-A_green	
A7	LED-B_red	- LED A: red (Error)
A9	LED-B_green	- LED B: green (Run/Activity)
A11	FC1_I2C-SDA	I <sup>2</sup> C 1: detection of motherboard type via external EEPROM
A13	FC1_I2C-SCL	
A15		Reserved
A17		Reserved
A19	Ext-CAN-Sel#	Alternative, external CAN transceiver is used if put on ground
A21		Reserved
A23		Reserved
A25		Reserved
A27	Dout-0	Digital outputs 0 to 7 for switching external output drivers, 3.3 V level
A29	Dout-1	
A31	Dout-2	
A33	Dout-3	
A35	Dout-4	
A37	Dout-5	
A39	Dout-6	
A41	Dout-7	
A43	CAN-H	High-speed CAN ISO 11898-2: differential signal High
A45	CAN-L	High-speed CAN ISO 11898-2: differential signal Low
A47	Reset-in#	Module reset, Low-active, internal pull-up 10 kΩ to 3.3 V
A49	GND	Ground



<b>Pin MMFD</b>	<b>Name</b>	<b>Function</b>
A2	GND	Ground
A4		Reserved
A6		Reserved
A8		Reserved
A10		Reserved
A12		Reserved
A14		Reserved
A16		Reserved
A18		Reserved
A20		Reserved
A22		Reserved
A24		Reserved
A26		Reserved
A28		Reserved
A30		Reserved
A32	Boot-CAN#	CAN bootloader is started if ground connection exists during start-up (CAN pins: A43, A45)
A34		Reserved
A36		Reserved
A38		Reserved
A40		Reserved
A42	Ext-CAN_M1	
A44	Ext-CAN_M0	Connection to alternative, external CAN transceiver(is enabled with pin A19)
A46	Ext-CAN_TxD	
A48	Ext-CAN_RxD	
A50	GND	Ground

<b>Pin MMFD</b>	<b>Name</b>	<b>Function</b>
B1	GND	Ground
B3	FC0_V24_TxD	Serial RS-232 interface for firmware updates
B5	FC0_V24_RxD	
B7	FC0_V24_RTS	
B9	FC0_V24_CTS	
B11		Reserved
B13		Reserved
B15	ID_Bit-0#	Module ID (4 bits values 0 – 15): - Pin open (internal pull-up): 0 - Pin on ground: 1
B17	ID_Bit-1#	
B19	ID_Bit-2#	
B21	ID_Bit-3#	
B23	Vbus	
B25	USB1_P	Connection to a USB host (PC) for firmware update
B27	USB1_N	
B29		Reserved
B31	Din 0	Digital inputs 0 to 7, 3.3 V level
B33	Din-1	
B35	Din-2	
B37	Din-3	
B39	Din-4	
B41	Din-5	
B43	Din-6	
B45	Din-7	
B47	3V3in	Supply voltage input 3.3 V DC, 100 mA (connected to B48)
B49	GND	Ground

Pin MMFD	Name	Function
B2	GND	Ground
B4	Boot-Serial#	Bootloader is started if ground connection exists during start-up (RS-232 pins: B3, B5, B7, B9)
B6	Boot-USB#	USB bootloader is started if ground connection exists during start-up (USB pins: B23, B25, B27)
B8	Fout-0	Frequency outputs 0 and 1, 3.3 V level
B10	Fout-1	
B12		Reserved
B14		Reserved
B16		Reserved
B18		Reserved
B20		Reserved
B22		Reserved
B24		Reserved
B26		Reserved
B28	Ain-0	Analog inputs 0 to 7, resolution 12 bits
B30	Ain-1	
B32	Ain-2	
B34	Ain-3	
B36	Ain-4	
B38	Ain-5	
B40	Ain-6	
B42	Ain-7	
B44	Vref-out	Reference voltage 3.0 V, can be connected to pin B46 as internal reference
B46	Vref-in	Reference voltage input for 12-bit ADC, pin B44 recommended as source
B48	3V3in	Supply voltage input 3.3 V DC, 100 mA (connected to B47)
B50	GND	Ground

## 2.2 Circuitry

For the basic operation of the PCAN-MicroMod FD, a **minimal circuitry** with the following components is required:

- Voltage supply 3.3 V DC
- CAN connection (CAN-High, CAN-Low)
- Pull-Down for module ID inputs
- Feedback of the analog reference voltage
- Push button to ground for CAN flash mode (with pull-up resistor)
- Reset push button to ground

The minimum circuitry is shown in the circuit diagram in Appendix B on page 22.

A **comprehensive circuit example** can be found in the circuit diagram for the separately available Evaluation Board. The circuit diagram is part of the corresponding user manual PCAN-MicroMod FD Evaluation.



**Tip:** When designing the circuitry for the PCAN-MicroMod FD, also observe the protection against overvoltage and reverse polarity at inputs.

# 3 Operation

## 3.1 Status LEDs

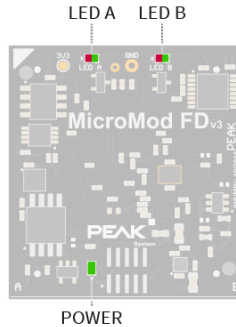

Figure 2: Positions of status LEDs on the PCAN-MicroMod FD

<b>LED A (upper left)</b>	<b>Status</b>	<b>Description</b>
No function		Reserved

<b>LED B (upper right)</b>	<b>Status</b>	<b>Description</b>
Green blinking (1 Hz)	Normal operation	
Green quick blinking (2 Hz)	No valid configuration	
Orange quick blinking (4 Hz)	CAN bootloader	Ready for transfer. New firmware can be transferred to the PCAN-MicroMod FD via CAN bus using the Windows program PCAN-Flash.
Red on	Firmware error	The PCAN-MicroMod FD does not have a valid firmware.

<b>Power LED (lower location)</b>	<b>Status</b>	<b>Description</b>
Green on	Supply	The supply voltage of 3.3 V is applied to the PCAN-MicroMod FD.

## 3.2 Reserved CAN ID 7E7h

The CAN ID 7E7h is used to configure the PCAN-MicroMod FD. The PCAN-MicroMod FD Configuration program exchanges data with the module via the CAN bus accordingly. When planning your CAN network, make sure not to use the CAN ID 7E7h elsewhere.

## 3.3 Overview of Services

The PCAN-MicroMod FD provides various functions, called services. The availability of services depends on the used motherboard.

<b>Service</b>	<b>Remark</b>
Symbols (CAN messages)	Definition of the CAN messages used by the PCAN-MicroMod FD with Symbol names (CAN ID) and Variables resulting from Signals within the data bits. Signals can contain initial values and timeout periods (e.g. for CAN problems).
Digital Inputs	Assigned CAN messages can also be transmitted event-controlled. For this purpose, the type of signal change (positive edge, negative edge or both edges) is set as trigger.
Digital Outputs	A Signal has influence either on the state of a digital output or on the duty cycle at a preset frequency.
Analog Inputs	An A/D value can be adjusted with scale and offset. Furthermore, a software low-pass can be activated.
Analog Outputs	This service is only available with a D/A converter being applied to the PCAN-MicroMod FD (e.g. using the Analog 1 motherboard). A D/A value can be adjusted with scale and offset.
Frequency Outputs	Frequency and duty cycle are controlled independently with one Signal each.
Digital Functions	The digital inputs can be logically combined with each other. The result can be passed on to a Signal, to a digital output, or internally as feedback to an input.
Statistics	Statistical data generated by the PCAN-MicroMod FD about the processing and the environment can be passed to Signals.
Curve Definitions/Curves	Analog input data can be converted with the help of curves.

Service	Remark
Rotary Encoders	The service can process the signals of manual encoders (standard quadrature with 2 bits) connected to digital inputs. Input frequency max. 100 Hz.
Functions	A collection of functions that convert one Signal value and place the result on another Signal. Excerpt from the collection: Mult, Mod, And, Hysteresis, Limit, RS Flip Flop, Switch Delay, Greater Than.

Find more details about the functionality and the application of the services in the help of the PCAN-MicroMod FD Configuration program.

# 4 Configuration Program

With the enclosed configuration program PCAN-MicroMod FD Configuration for Windows you can create, edit, and then transfer configurations to one or more PCAN-MicroMod FD via CAN.

## 4.1 Prerequisites for the Configuration Transfer

- Windows 10, 8.1, 7 (32/64-bit)
- PC-CAN interface from PEAK-System, e.g. PCAN-USB FD
- CAN bus connection between PCAN-MicroMod FD and the CAN interface attached to the PC

On a computer without PCAN environment, you can create and edit a configuration and later on transfer it with another computer PC-CAN interface to the PCAN-MicroMod FD.

## 4.2 Installing the Configuration Program

The setup program for PCAN-MicroMod FD Configuration is on the provided Product DVD.

Steps of the software installation:

1. Insert the Product DVD into the computer drive and execute the navigation program either on request or manually (`Intro.exe`).
2. Click on *English > Tools*.
3. In the list, find the *PCAN-MicroMod FD Configuration* entry and click on *Install*.
4. Follow the instructions of the setup program.



Retrieve further information about the use of PCAN-MicroMod FD Configuration in the provided help that you can reach via the program (e.g. with the **F1** key).

# 5 Firmware Update

Different ways are available in order to update the firmware on the PCAN-MicroMod FD.

Way	Pins for transfer	Pin for flash mode*	File type	Required supplements
RS-232	B3: TxD, B5: RxD	B4	Hex	Flash program <a href="#">Flash Magic</a> for Windows
CAN	A43: CAN-H, A45: CAN-L	A32 (LED A blinks quickly orange)	Binary	PC-CAN interface from PEAK-System PCAN-Flash for Windows (freely available)
USB	B23: Vbus, B25: USB1_P, B27: USB1_N	B6	Binary	None (mass storage device in operating system)

\* Must be connected to ground during switch-on.



**Tip:** In order to update the firmware, we recommend the use of the Evaluation Board for the PCAN-MicroMod FD (IPEH-003081 or kit IPEH-003082). On the one hand, this simplifies the connection of the cabling, on the other hand the setting of the flash mode.

# 6 Technical Specifications

## Measures

Board size	33 x 36 mm
Height with pins	13 mm
	See also Appendix A <i>Dimension Drawings</i> on page 21
Weight	9 g

## Supply

Supply voltage	3.3 V DC
Current consumption	max. 180 mA

## Connectors

Connection strips	2 double strips, each with 50 pins
Grid	50 mil (1.27 mm)
	See also Appendix A <i>Dimension Drawings</i> on page 21

## Control and communication

Microcontroller	NXP LPC54618, Arm® Cortex® M4 Core
Standard firmware	Configuration via reserved CAN ID 7E7h

## CAN

Channels	1
Specification	ISO 11898-2, CAN 2.0 A/B and CAN FD
Transceiver	Microchip MCP2558FD
Nominal bitrates	20 kbit/s – 1 Mbit/s
CAN FD data bitrates	20 kbit/s – 10 Mbit/s
Galvanic isolation	none
Termination	none

## Inputs and outputs

Digital inputs	8
Analog inputs	8, 0 – 3 V unipolar, resolution 12 Bit, sample rate 1 kHz
Digital outputs	8
Frequency outputs	2
Temperature sensor	Measuring range -55 – +125 °C (-67 – +257 °F), fixed

## Additional data channels

USB	For firmware update, only via separately available evaluation board.
RS-232	For firmware update, only via separately available evaluation board und with separate flash software

## Environment

Operating temperature	-40 – +85 °C (-40 – +185 °F)
Temperature for storage and transport	-40 – +100 °C (-40 – +212 °F)
Relative humidity	15 – 90 %, not condensing

# Appendix A Dimension Drawings

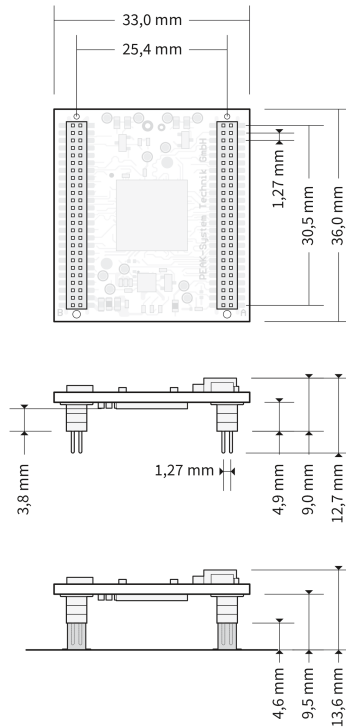

Figure 3: The scale of the drawings differs from an 1-to-1 representation.

Pitch of connection pins: 50 mil  $\hat{=}$  1.27 mm

Lower figure: example for plug-on positioning on a motherboard. Possible socket strip (2 pieces) as counterpart to the PCAN-MicroMod FD: Amtek 5PS3MSA44-225GONPNRU-00

# Appendix B Minimum Circuitry

The following circuit diagram shows the minimum circuitry required to operate the PCAN-MicroMod FD.

BOM1  
 MicroMod\_FD  
 MicroMod FD

